

Characterization of new trap detectors as transfer standards

J-M. Coutin, F. Chandoul, and J Bastie

LNE-INM / CNAM, 292 rue Saint-Martin, 75003 Paris, France

Abstract. The French radiometric references are based on a cryogenic radiometer working at a restricted number of laser wavelengths. The traceability to the cryogenic radiometer is implemented by using transfer detectors linked in absolute spectral responsivity to the cryogenic radiometer. To improve this traceability, we have been developing new trap detectors build with new Silicon HAMAMATSU photodiodes (part number Si-S8552 and Si-S855).

Introduction

The French national standard laboratory uses an electrically calibrated cryogenic radiometer as the basis for its optical radiation measurement scales. The purpose of the work in progress is to improve the traceability to the cryogenic radiometer of the various radiometric and photometric quantities measured. This traceability is implemented by using transfer detectors linked in absolute spectral responsivity to the cryogenic radiometer.

The cryogenic radiometer allows direct calibration of detectors in absolute spectral responsivity with a relative standard uncertainty in the range of 1 part in 10^4 , but only for a few laser wavelengths. In order to derive from these punctual spectral measurements all the radiometric and photometric quantities maintained by the laboratory, it is necessary to interpolate and eventually extrapolate the spectral responsivity of detectors used as transfer standards within their spectral range.

In order to facilitate and optimize the extrapolation and interpolation method, we use as transfer detectors large-area reflection silicon trap detectors. The objective is to take advantage of the main property of trap detectors : this type of detectors has an absolute spectral responsivity curve that can be modelled over the spectral range of useful wavelengths.

Description of the trap detectors

In our laboratory, we use as secondary standards trap detectors, which are the only detectors able to maintain and transfer the accuracy reached with the cryogenic radiometer. These traps are three element photodiode reflectance traps, built with three $10 \times 10 \text{ mm}^2$ Silicon photodiodes having very high internal quantum efficiency^[1]. But due to their geometry, they have a small area and a very limited field-of-view (FOV), so it is difficult to use them with large or not parallel beam of radiation.

In order to take advantage of the properties of trap detectors and minimize the geometrical limitation, we are studying large-area reflection silicon trap detectors, where three large-area Silicon photodiodes with an active area of $18 \times 18 \text{ mm}^2$ are used. Figure 1 shows the scheme of the trap detectors we developed², and the arrangement of the three photodiodes inside the trap : the incident beam (arrows on figure 1) is absorbed 5 times before coming out

of the trap. Due to their larger area and their wider FOV, these detectors can be used much more easily at the exit of the monochromator, in our set-up for spectral responsivity measurements.

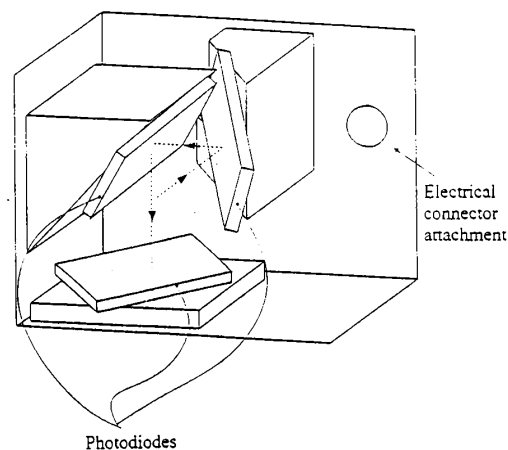

Figure 1. Scheme of principle of a large-area reflectance trap.

The first prototypes of large-area trap detectors that we studied are made with large-area windowless HAMAMATSU photodiodes (part number S3204-09)³. But the photodiodes mounted in these trap detectors are not suitable for the realization of trap detectors, because their reflection factor is near zero in the visible range. In addition, the measured quantum efficiency of this type of trap detector is not sufficiently close to the unity to develop easily a valuable model for the spectral responsivity.

In order to continue our study and improve the first results, we investigated the large-area Silicon windowless photodiodes proposed by HAMAMATSU. We found out new Silicon photodiodes of type S8552 that seems to be more appropriate to the problem. Furthermore, these photodiodes are designed to provide optimal performance in the VUV range and offer more stable sensitivity even after long exposure to VUV radiation, compared with conventional type. So we are now studying new trap detectors made with these photodiodes in order to make new standard detectors over the spectral range 190 nm – 1000 nm.

Characterization of the trap detectors

We are studying two types of new trap detectors. The first type is made with $10 \times 10 \text{ mm}^2$ Silicon photodiodes (part number S8552) to be used as secondary standards detectors, and especially in the VUV range. In Figure 2 are shown the results of the calibration of this detector in spectral responsivity at some laser wavelengths. The measurements were made by comparison with the cryogenic radiometer, with an uncertainty of the order of 1.5 parts in 10^4 ⁴. The results are very encouraging for the use of this detector as secondary standard, because the

variations of the spectral sensitivity, according to the wavelength, are relatively linear (better than 1 part in 10^3) on the whole of the measurement points. In addition, the values obtained for the spectral sensitivity are very close to the theoretical curve of trap detectors, which is obtained for quantum efficiency equal to one.

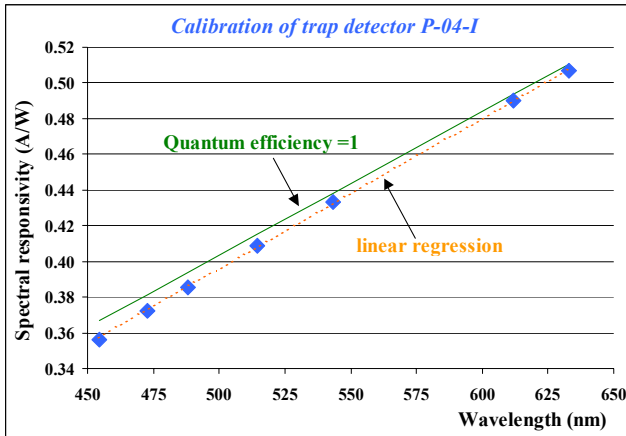

Figure 1. Results of the calibration of a small-area trap detector made with S8552 photodiodes

The second type of trap detectors we developed are made with large-area windowless HAMAMATSU photodiodes (part number S8553), to use them as transfer detectors for radiometric and photometric measurements. The absolute responsivity measurements are carried out at some laser wavelengths by comparison with the secondary standard trap detector described above, with an uncertainty of the order of 2 parts in 10^4 . The results are similar to thus obtained with the small-area trap detector made with the same type of photodiodes.

To take into account the possible variations of local responsivity, and to become closer to the using conditions, which correspond to a surface of the detector much more irradiated, than during the calibration with laser beam, the spectral responsivity has been measured in various points around the centre of the active area of the detector, for two perpendicular positions of the detector. The results are shown in figure 3 : the modification of the method of calibration allowed to underline a variation of the spectral sensitivity between the two measurement positions of the detector, which is in the order of 4 parts in 10^4 . But the relative uncertainty on the global value of the spectral sensitivity, for each laser wavelength, is in the order of 1 part in 10^4 . The resulting global uncertainty on the calibration is then 2 to 3 parts in 10^4 that is quite acceptable.

To use the detector as standard transfer detector, it is necessary to determine the spectral responsivity of the trap detector over it using spectral range, and not only at laser wavelengths. The absolute values are then interpolated and extrapolated by comparing the trap detector to a non-selective cavity shape pyroelectric detector, on the spectral responsivity measurements set-up.

Figure 3. Local variations of the spectral responsivity obtained for the two measurement positions of the large-area trap detector

Conclusion

The determination of the absolute spectral responsivity, by using the pyroelectric detector as means of interpolation and extrapolation, can not be obtained with an uncertainty better than 1 and 2 parts in 10^{-3} that does not allow yet to improve the whole radiometric measurements notably. At present time, we are continuing the characterization of these detectors and are trying to find a mathematical model for the spectral responsivity that can permit to improve the uncertainty on the absolute values of spectral responsivity. The aim of this study is to obtain transfer detectors based on these new large-area trap detectors, to be able to maintain and transfer accurately spectral responsivity measurements with an uncertainty better than 5 parts in 10^4

References

- [1] Fox N., Trap Detectors and their Properties, *Metrologia*, vol.28, 1991, p.197-201
- [2] The mechanical parts of these trap detectors were bought at the AS RANTELL Company, in Estonia. The mechanical design was studied by the Metrology Research Institute of the Helsinki University of Finland in collaboration with the department of Physics of the University of Tartu in Estonia
- [3] Coutin J.-M., Tayeb F., Bastie J. Development of large area trap detectors for improving spectral responsivity measurement of detectors at the BNM-INM, *Proceedings of the 25th Session of the CIE*, San Diego, USA, 25 June - 2 July; 2003, Vol.1, pages D2-50,D2-53 (CIE 152:2003 ISBN 3 901 906 21 5)
- [4] Coutin J.M., Touayar O., Bastie J., The using conditions of the BNM-INM cryogenic radiometer as the basis for the French optical radiation measurement scales, *24th session of the CIE, Varsovie*, 24-30 Juin 1999, Proceedings vol. 1 part. 1, p. 729-732.

